

Double Door Over Bath Slider (V2 ~ Semi frameless).

Installation / Maintenance Instructions

rev 04.11

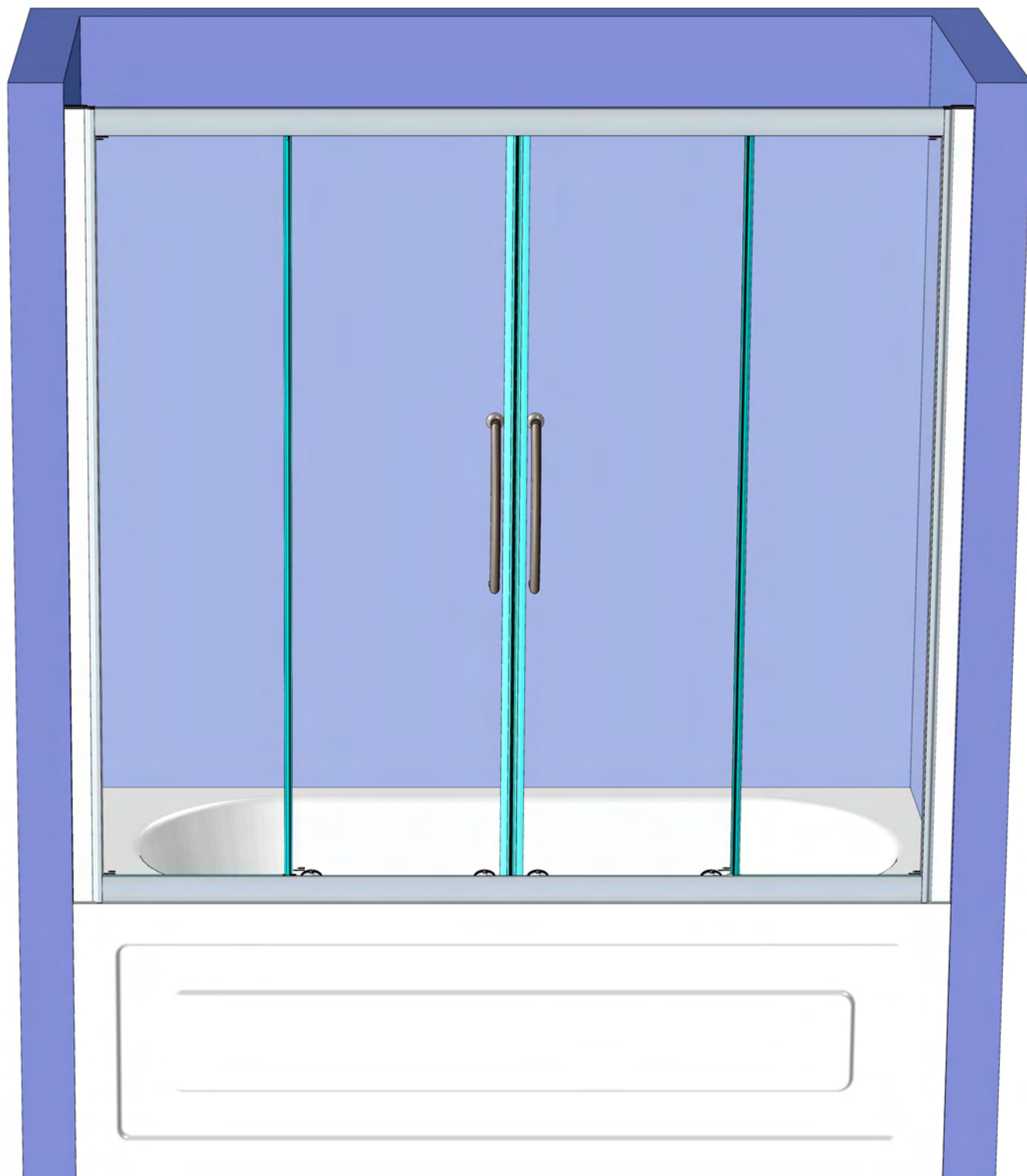

Lakes

Bathrooms

IMPORTANT NOTES :

Please Read Carefully & retain these instructions for Future Reference.

1. For ease & safety we advise that two persons assemble this product.
2. Protect bathtub surfaces at all times.
3. Check for cables, pipes etc before drilling walls.
4. Ensure all surfaces are dry, clean & free of loose debris / dust.
5. Unpack goods with care (small parts can become lodged in packaging & inadvertently discarded). Check parts supplied against parts & fittings listed herein. Damaged parts / omissions may be resolved by calling Lakes Bathrooms Helpline.
6. Whilst precautions are taken in manufacture, care must be taken when handling as rail ends may have sharp edges.
7. Before commencing, check :
 - a) bathtub is level & completely sealed to finished / tiled walls.
 - b) finished walls are sound & free of cracks loose tiles / grout.
8. AFTER INSTALLATION, DO NOT 'WET' ENCLOSURE FOR 48 HOURS (ENSURE FULL CURE OF SILICONE SEALANT).

USE :

General Care & Maintenance.

Provided this product is installed & operated in accordance with these instructions, problems should not arise. However should maintenance be required it should be carried out by a competent person with reference to these instructions. Before any work is carried out the root cause of the problem must be identified. Lakes Bathrooms service engineers are available if necessary to consult / carry out remedial work. Call Lakes Bathrooms HELPLINE.

Cleaning.

(Every one to two weeks depending on local water {hardness} conditions).

All glass panels in this product have a hydrophobic coating aiding 'runoff' of water droplets, reducing the need for frequent cleaning. For best appearance / product life however, regular cleaning is recommended.

Use ONLY mild soap / detergent solutions to clean. Rinse with water, squeegee glass panels & wipe frames dry with a soft cloth. Under no circumstances should abrasive, caustic or scouring products be used. Cleaning products should have pH value 4 ~ 8. DO NOT use 'spray & leave' type cleaning products. Non compliance with these cleaning instructions may cause plated / painted finishes to deteriorate & could adversely affect safe operation of the enclosure.

Limescale ~ should a build up of limescale occur, remove using a 50:50 solution of white vinegar & water applied with a soft cloth & rinsed / dried thoroughly afterwards.

Daily Care.

To prevent the build up of limescale, do not allow water droplets to dry on glass or frames. After showering, rinse with water, remove droplets from glass with a squeegee & wipe frame with a soft cloth.

Customer Service.

Quality Guarantee : Lakes Bathrooms Ltd guarantee Shower Doors & Enclosures against any manufacturing or material defects for the lifetime of the product. We will resolve defects free of charge by repairing / replacing parts as we feel necessary. To be 'free of charge' service work must be carried out by Lakes Bathrooms or approved agents.

Not Covered by this Guarantee : Damage or defects that result from improper installation, improper use, or lack of maintenance (including limescale buildup). Damage or defects that result from repairs / modifications undertaken by unauthorized persons. This guarantee is in addition to statutory & other legal rights.

What to do if something goes wrong : Should the product not function correctly on initial use, firstly, contact the installer to check that unit installation & commissioning are in accordance with these instructions. Should this not resolve difficulties or should performance decline, consult 'Troubleshooting' section to see if simple home maintenance is needed. Alternatively our HELPLINE staff can assist, or if necessary arrange for a service engineer to visit.

Spares : We maintain extensive spare part stocks. Spares can be ordered / purchased from your retailer in the first instance. Parts will normally be dispatched within two working days from order placement.

Pro Forma invoices will be sent for cheque payments.

SUPPLIED PARTS :

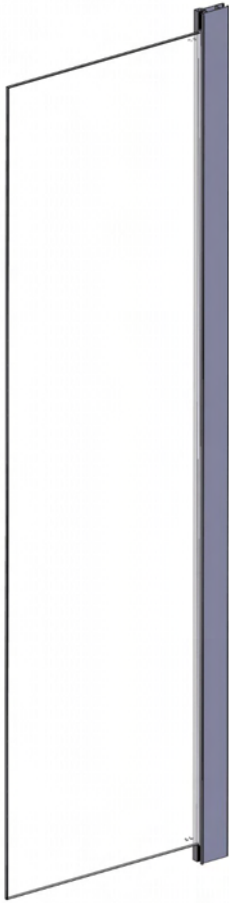

Panel Sub Assy (2x)
Fig B



Door Glass (2x)
fig D

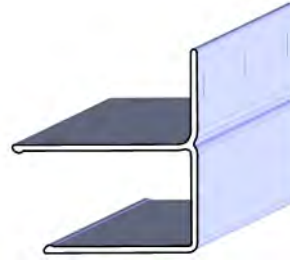

Wall Rail 1500mm
(2x) Fig A



Horizontal Rail
(2x) fig B

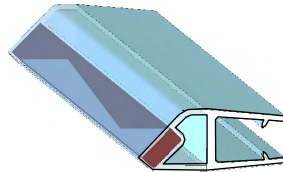

Magnetic Seal
(2x) fig E

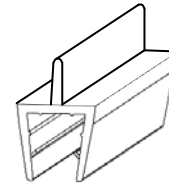

Horizontal
Glazing
Seal (4x) fig B

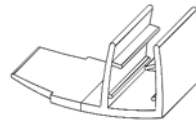

Edge Seals (fig E)
1817mm (2x)



Doorstop
Buffer (8x)

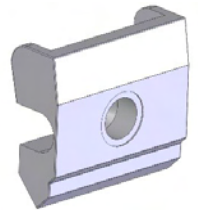

Doorstop
Block (8x)

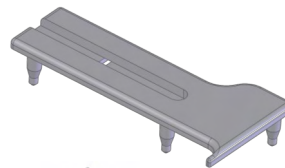

Top Cap (Vertical Profile)
(handed pair)

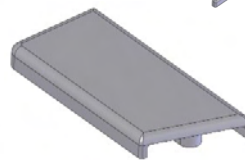

Top Cap (Wall Profile)
(handed pair)

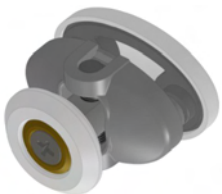

Top Wheel
Assy (4x) fig D



Handle Kit
(2x) fig D



3,5 x 40 long self tapping
screw (8x) fig B



4 x 45 long self tapping
screw (6x) Fig A



7,5 x 39mm Wall Plug(6x) Fig A



3,5 x 12 long CSK self tapping screw
(12x) fig B & F



3,5 x 10 long Pan Head self tapping
screw (6x)



Cup Washer (12x) fig



Decorative Screw Cover Cap (12x) fig C



Decorative Screw Cover Cap (12x) fig B

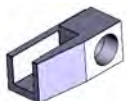

Glazing Block (2x handed pair) fig B

Size ref	Adjustment Range (Dim'n A)
1500mm	1440 to 1500mm
1600mm	1540 to 1600mm
1700mm	1640 to 1700mm
1800mm	1740 to 1800mm

Tools Required

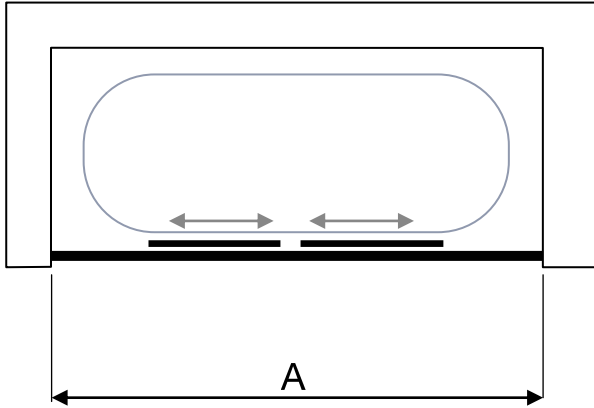
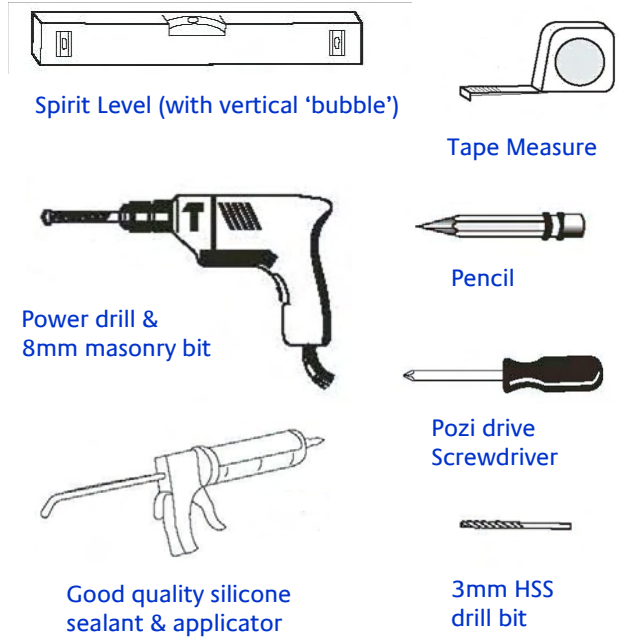

Ensure bathtub is completely level & that tub / wall (tile) joints are sealed & cured over entire length of bathtub sides (See Fig A) prior to fitting enclosure.
DO NOT SEAL TRAY EDGES UPTO A FITTED ENCLOSURE !

A

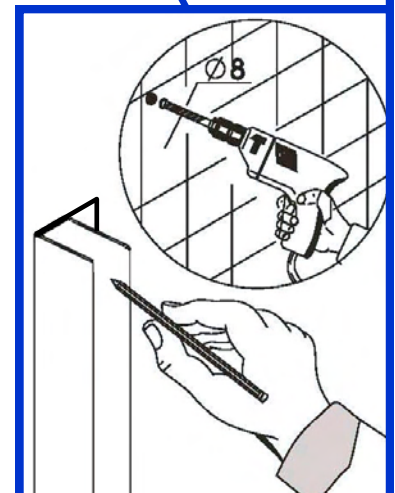
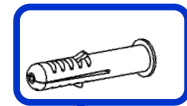
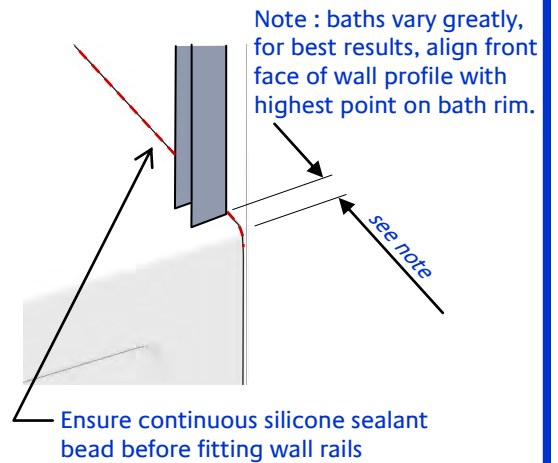
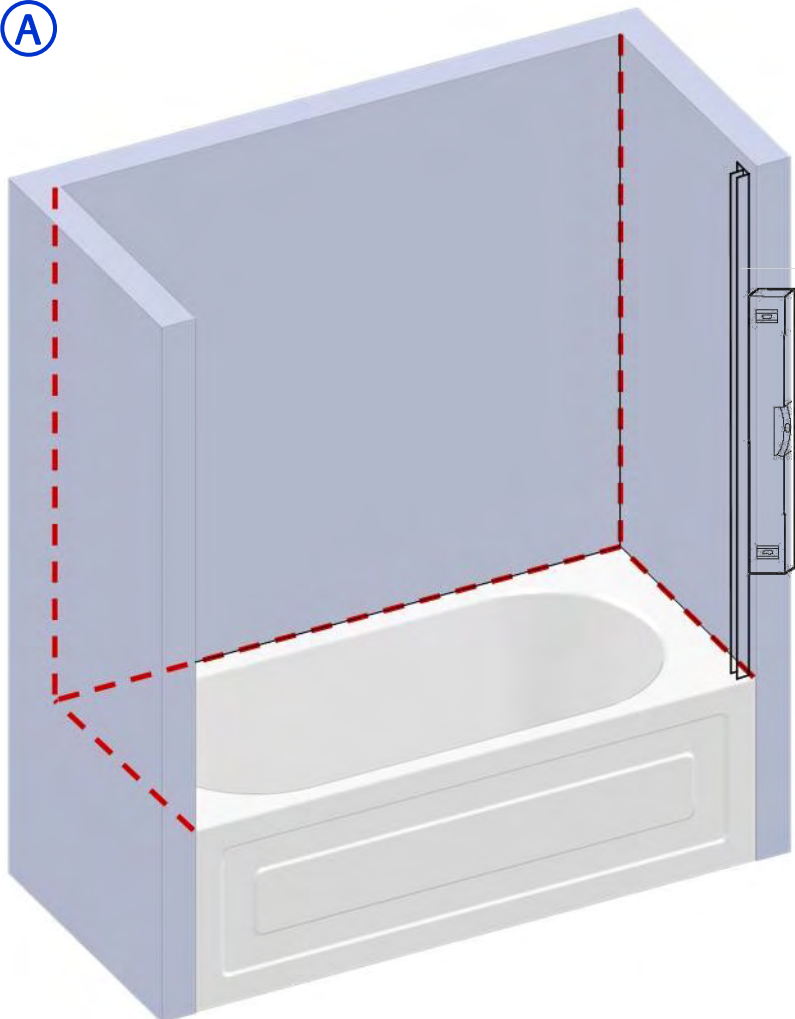

Wall profile orientation : Wall flange to shower side. Measure & mark wall rail positions. Drill & plug walls only at this stage.

MAIN FRAME SUB ASSEMBLY: (typical 4 corners)

(B)

1. Fit horizontal glazing seals to top & bottom edges of panel glass. Ensure seal is pushed up against vertical rail.
2. Align horizontal rail & affix with 3,5 x 40 long screws (2 per corner).
3. On tightening screws, ensure Gaskets are not 'pinched' in joint between rails.

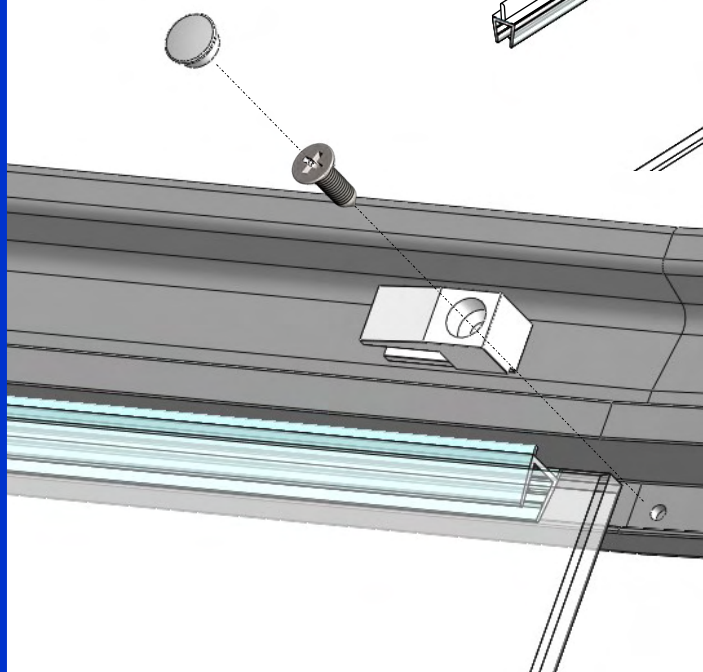
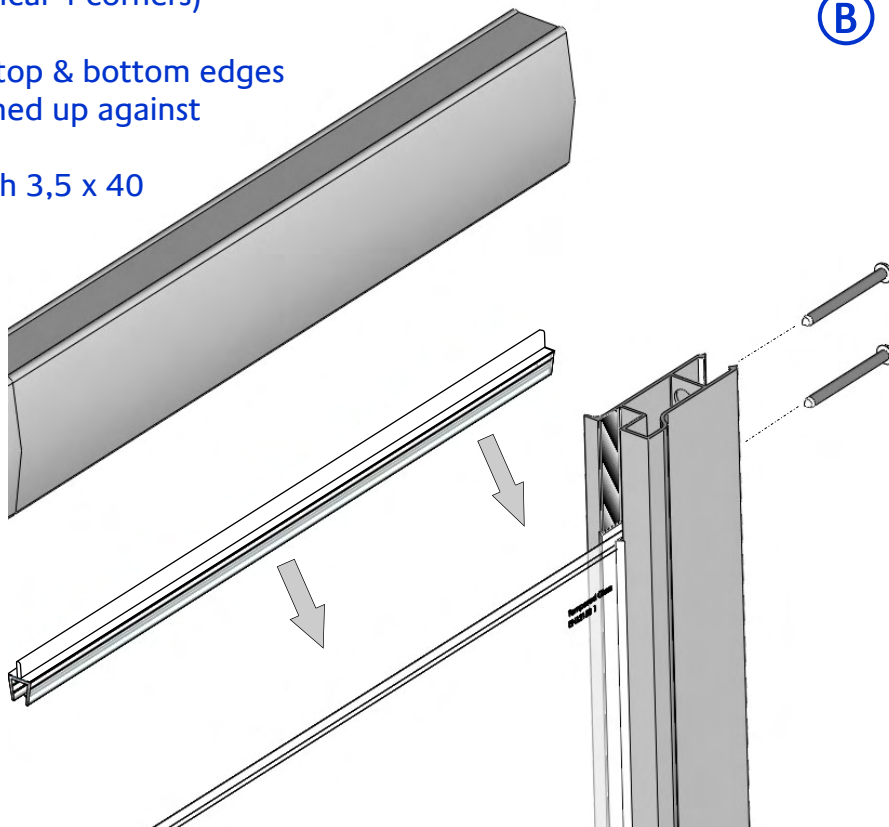

4. Align & fit glazing blocks with 3,5 x 12 long screws & fit decorative cover caps (4 places).

5. Lightly fit wall profiles to main frame (both sides) & compress until unit will fit alcove.

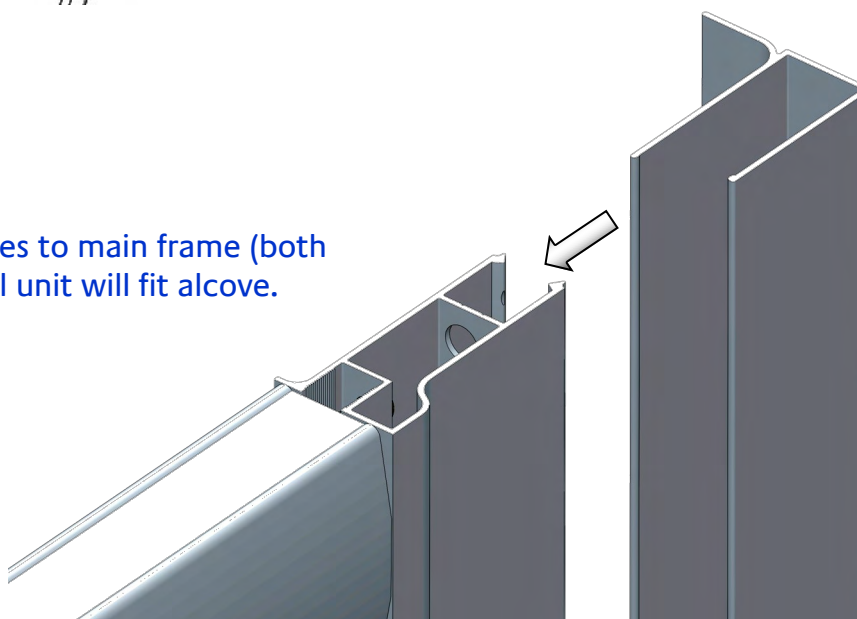

MAIN FRAME SETUP :

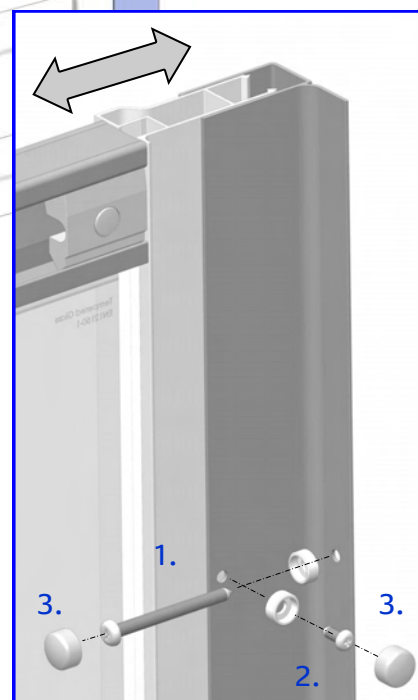
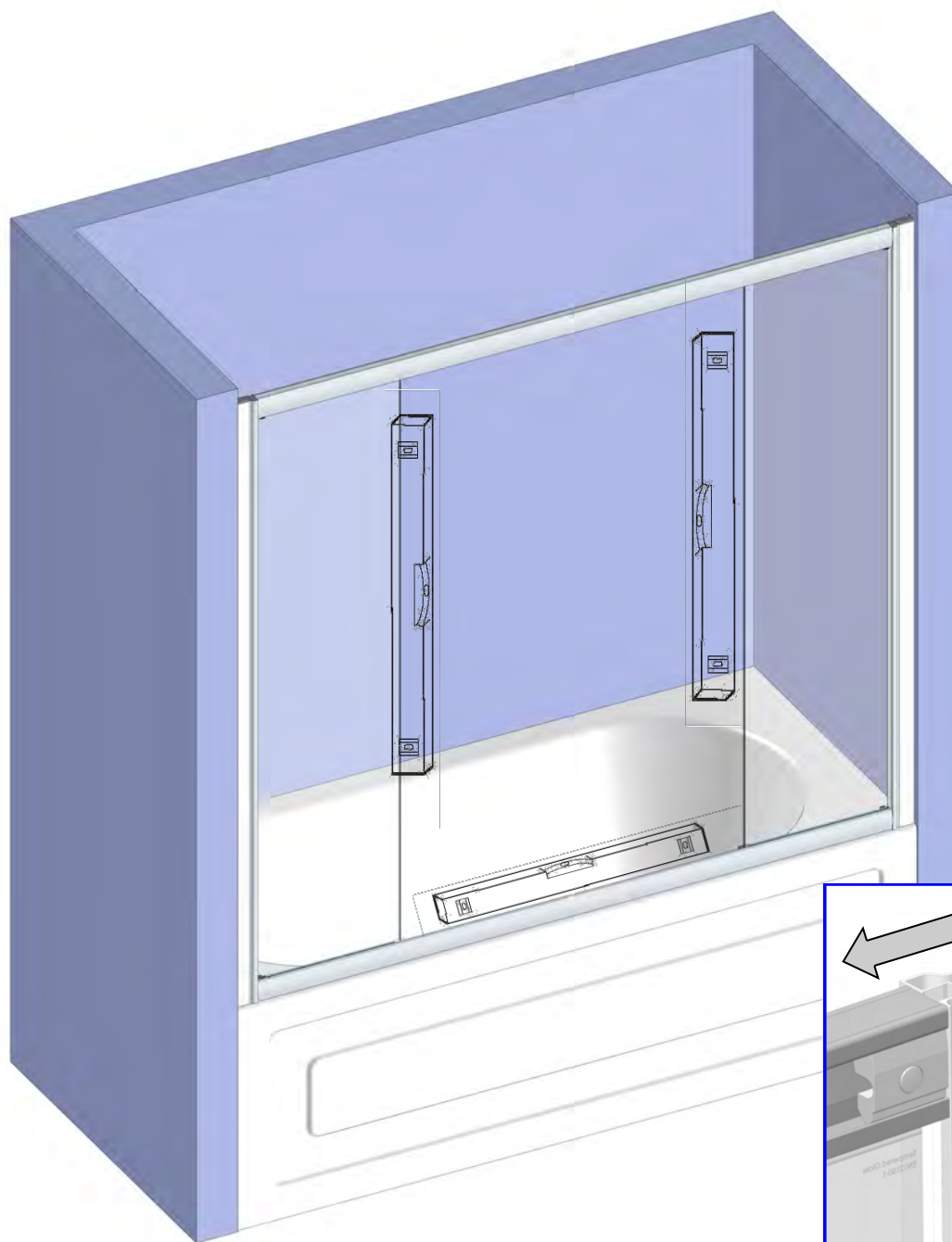

Lift frame into position, then from inside enclosure,

1. Align wall profiles with wall plugs & affix wall profiles to both walls using cup washers & 4 x 45mm screws (6 places).

Manipulate frame within wall profiles until centred & ensure frame is completely plumb (check both sides) .

2. From inside enclosure, using the wall profile holes as a guide, drill (3mm) & screw frame to wall profiles using cup washers & 3,5 x 10mm screws.
3. Fit all decorative caps (12 places total).

DOOR ASSEMBLIES :

Wheels must be fitted to top & bottom of door glass as shown.



Left Hand

Right Hand



Loosely fit top wheels at this stage (adjusting screw head to underside). Ensure screws are engaged in body, but do not tighten fully & do not fit cover.

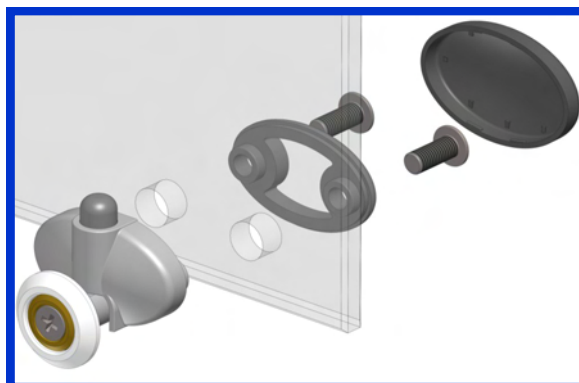

Fit & fully tighten bottom wheel, including cover

DOOR HANGING & SEALS :

E

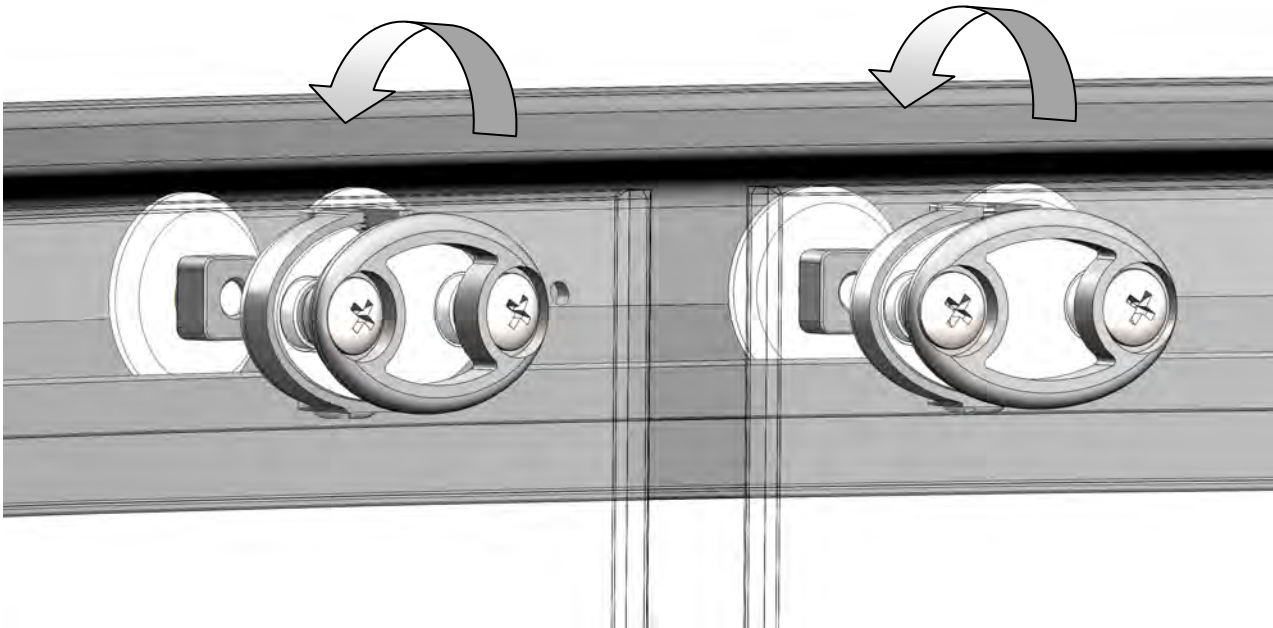

With wheel body loose on glass (screws engaged but not tightened) lift door & engage wheels in top rail & immediately tighten clamping screws.

Using buttons, engage bottom wheels in bottom rail.

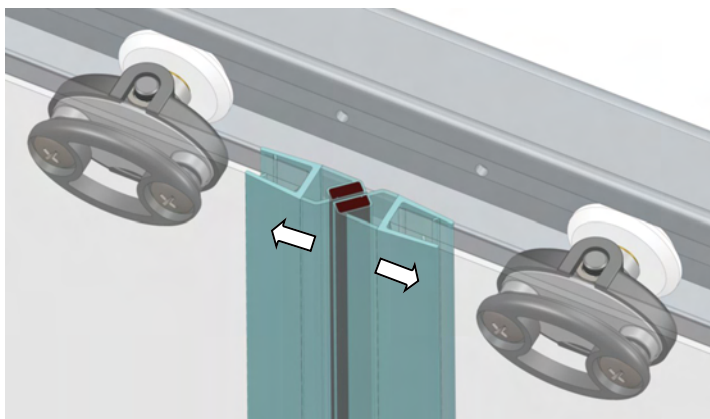
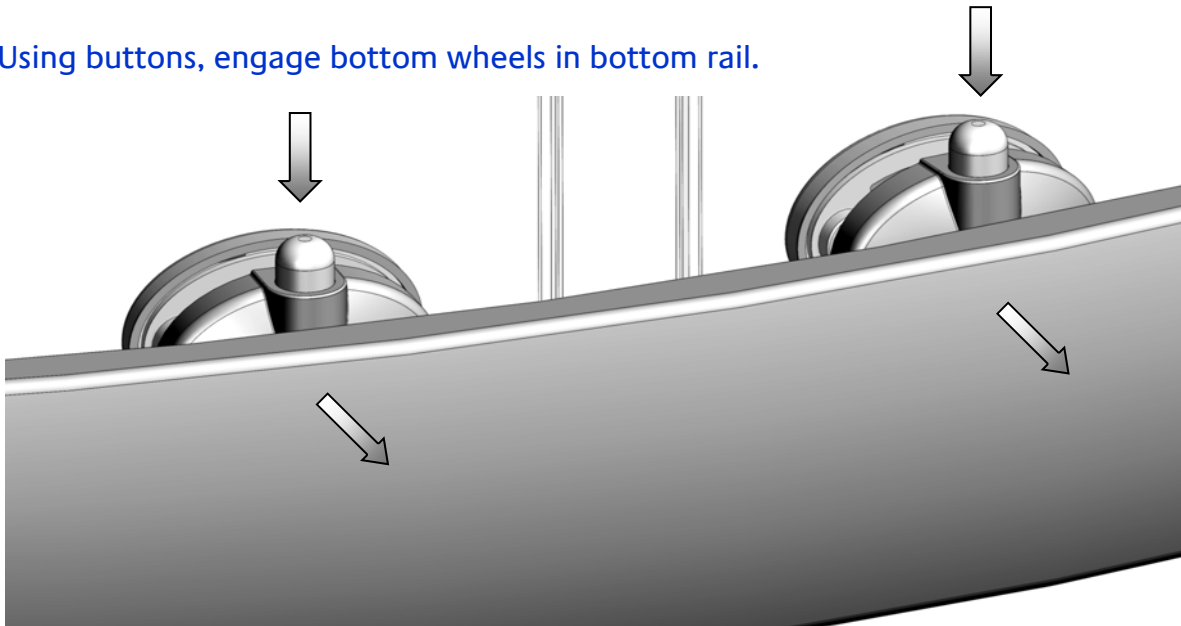

Fit magnetic seals to leading edges of doors.

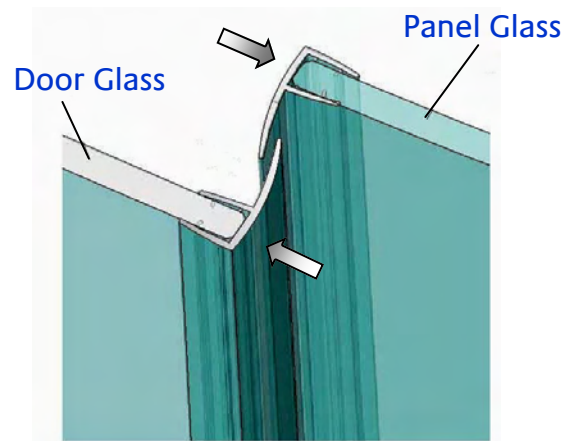

Fit edge seals to trailing edges of doors & open edges of fixed panels.

Seals may be 'Wetted' to ease assembly.

DOOR ADJUSTMENT / DOORSTOPS :

F

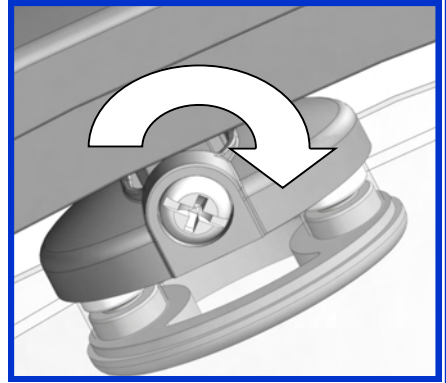
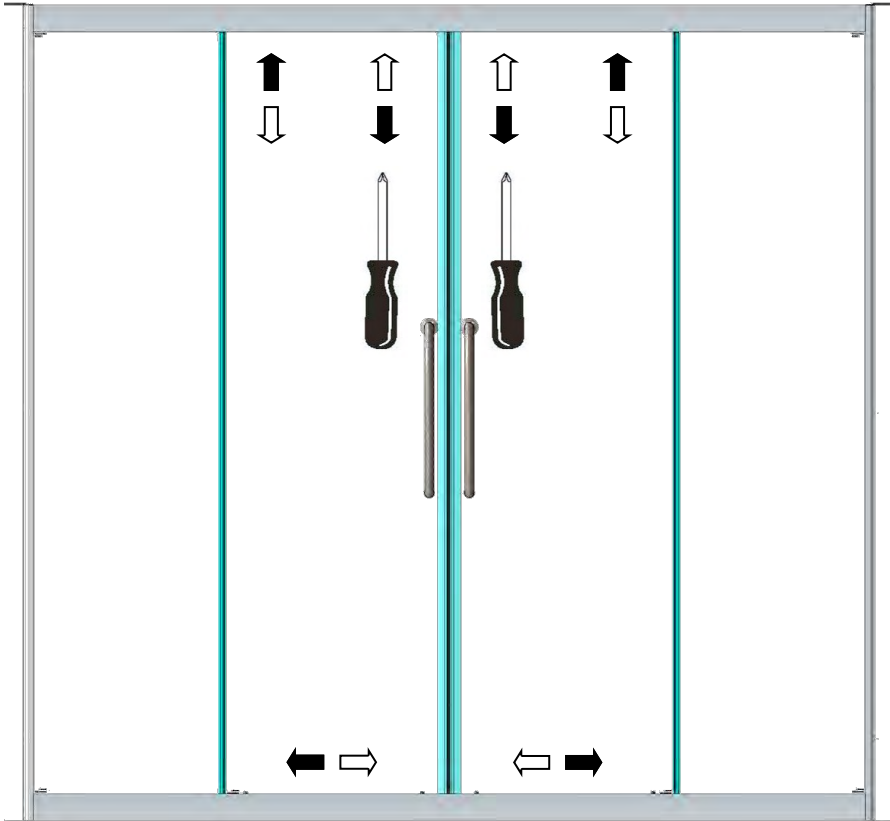

Adjust door heights until even & doors run smoothly. Adjust door angles so that magnetic seals hold door closed with no gaps.



After adjusting, check that clamp screws are tight & fit covers to top wheels

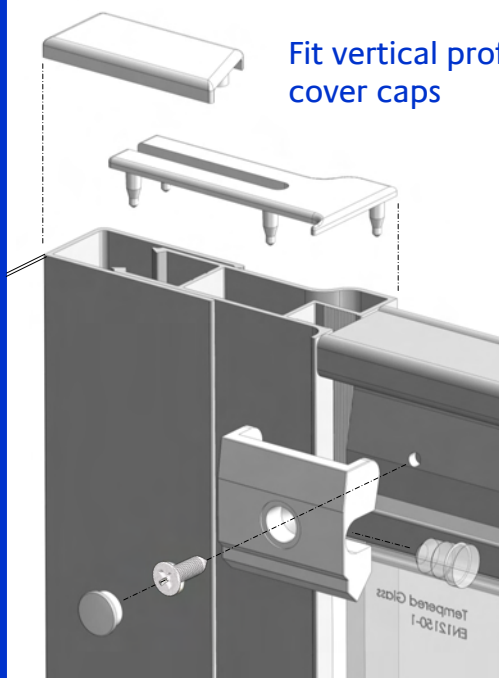

Fit vertical profile top cover caps

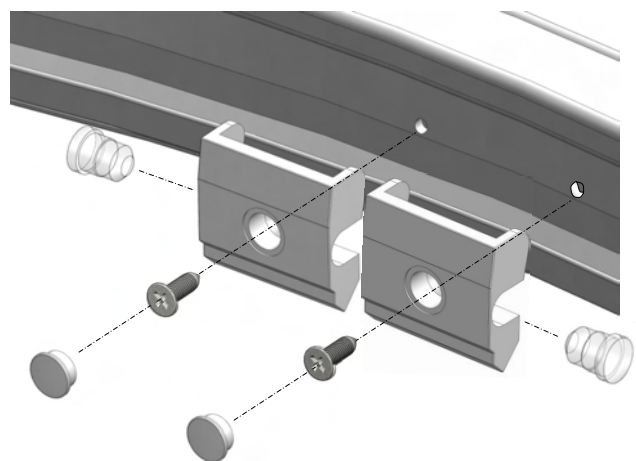

Fit doorstops with 3,5 x 12LG screws, fit caps & doorstop buffers

SEALING :

Ⓒ

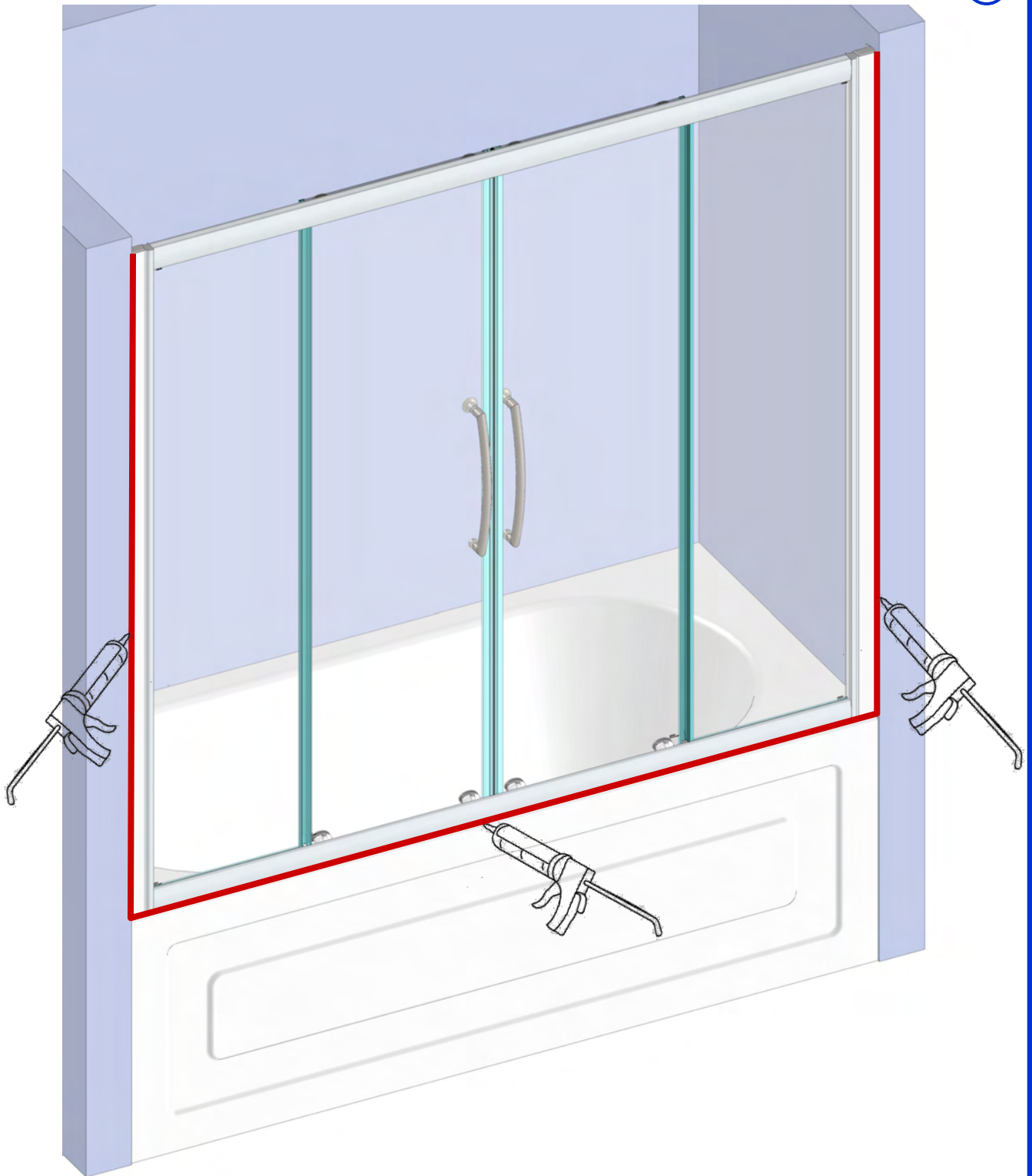

Use of good quality silicone sealant & cleaning / degreasing of all joint areas is recommended.

Apply continuous silicone sealant bead as indicated EXTERNALLY ONLY

BASIC TROUBLESHOOTING :

Door magnetic seals not meeting precisely / not holding :

Ensure magnetic seals are pushed fully onto door edge over entire door length.

Check door alignments & adjust if necessary (see fig F).

Check Magnetic Seal orientations (reverse if necessary).

Door motion noisy / Door not running smoothly / Door loose on bottom rail :

Check for edge seals dragging on glass (can cause 'clicking' noise).

Check top wheels engaged properly in rails & roll smoothly along rails.

Check door height adjustment ~ raise doors so that spring loaded bottom wheels are in contact with & roll smoothly along bottom rail.

Wheels & Grooves are factory greased, however over time this may disperse or become contaminated by dust etc, cleaning of grooves & re application of sanitary silicone based grease will restore & ensure smooth door motion.

Leakage :

The sealing method described in these instructions relies on a continuous seal being applied between shower walls & tray before installing the enclosure (see fig A), it ensures a watertight seal around the perimeter of the enclosure to the shower walls & tray.

In the unlikely event of an enclosure leak, water will be visible on the outside of the enclosure itself, or around the perimeter silicone seal ONLY. Water / moisture appearing outside this area (ie at floor level) is normally due to incorrect tray installation.

Lakes

Bathrooms

Lakes Bathrooms Ltd

5800 Shannon Place
Tewkesbury Business Park
Tewkesbury
GL20 8SL

Service England, Scotland, Wales

8.30am—5pm Mon ~ Thurs
8.30am—4.30pm Fri

Tel / HELPLINE : 01684 853870
Fax : 01684 276979

Service : Northern Ireland
Ian A Kernohan
Firtrees
Green Way Industrial Estate
Conlig
Northern Ireland
BT23 7SU

8.30am—5pm Mon ~ Thurs
8.30am—4.30pm Fri

Tel : 02891 270233
Fax : 02891 270597
Email : info@iakonline.co